



**FINE EQUIPMENTS**

*Raising benchmarks of aftersales service*



Lombardini Kohler KD 441 Engine

Easy to Operate & Transport

Highly Efficient & Reliable

Pan India on-site support

Fully Hydrostatic

## ***FINE WALK BEHIND ROLLER***



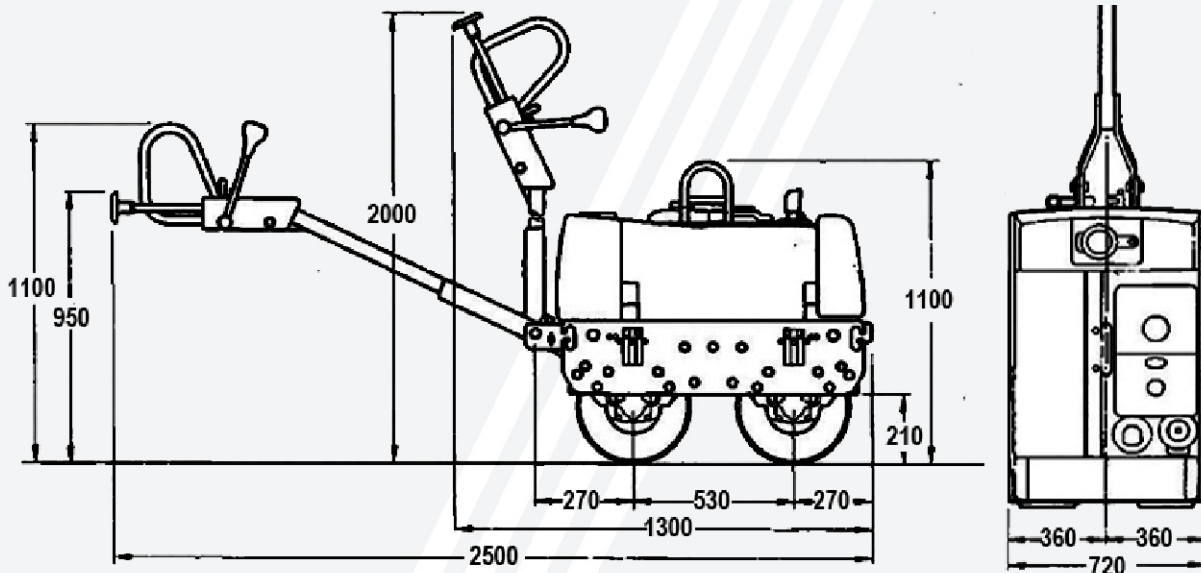

Note: All measurements in mm

### APPLICATIONS:

1. Hilly terrains with sharp bends
2. Culverts
3. Edges of highways
4. Parking lots
5. Internal Roads in Housing on Soil
6. Playgrounds
7. Granular and Asphalt etc
8. Gardening
9. Pavements
10. Compaction canals
11. Road Widening Works
12. Embarkments
13. Construction / repair of roads
14. Private roads

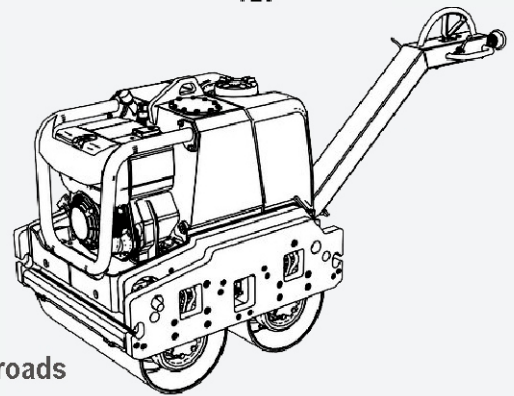

### SPECIFICATIONS:

#### Operating Data - fiV 6500

|                        |                |                           |                   |
|------------------------|----------------|---------------------------|-------------------|
| Basic Weight           | 780 Kgs        | Gradability               | 38%               |
| Drum width             | 650 MM         | Engine capacity           | 10 Hp             |
| Centrifugal force high | 24 kN          | Operating performance     | 7.4 kW @ 2600 RPM |
| Centrifugal force low  | 14 kN          | Tank capacity fuel        | 5 Liters - Diesel |
| Frequency Vibration    | 64 Kz          | Tank capacity water       | 35 Liters         |
| Amplitude drum         | 0.50 / 0.25 mm | Fuel consumption 1/h, avg | 1.2 L             |
| Travel speed - Maximum | 5.90 km / hr   | Travel speed - Minimum    | 2.50 km / hr      |

## PLATE COMPACTOR



### SPECIFICATIONS:

|                   |                  |
|-------------------|------------------|
| Net Weight        | 150 kg           |
| Engine            | Diesel - Greaves |
| Centrifugal Force | 20 kN            |
| Gradability       | 25%              |
| Plate Width       | 450 mm           |
| Plate Length      | 650 mm           |
| Total Width       | 450 mm           |



**FINE EQUIPMENTS (India) Pvt. Ltd.**

Behind Shroff Shrushti, Off Mumbai - Bangalore Highway,  
Mahalunge, Pune - 411 045.

website: [fineequipment.net](http://fineequipment.net)

Mobile: 9004 046 769  
8380 045 027

email: [info@fineequipment.net](mailto:info@fineequipment.net)