

**BOOM SWING
POWERFUL OPERATION
WORLD-CLASS SAFETY
EASY MAINTENANCE
ENVIRONMENT FRIENDLY
ROBUST AND COMFORTABLE
HYDRAULICALLY ADJUSTABLE TRACK**

mini

TB 219



In 1970 TAKEUCHI developed the world's first 2-ton class compact excavator (TB1000) having an independent boom swing structure. These so called mini shovels attracted a great deal of attention in the construction industry and opened an entirely new opportunity in global market.

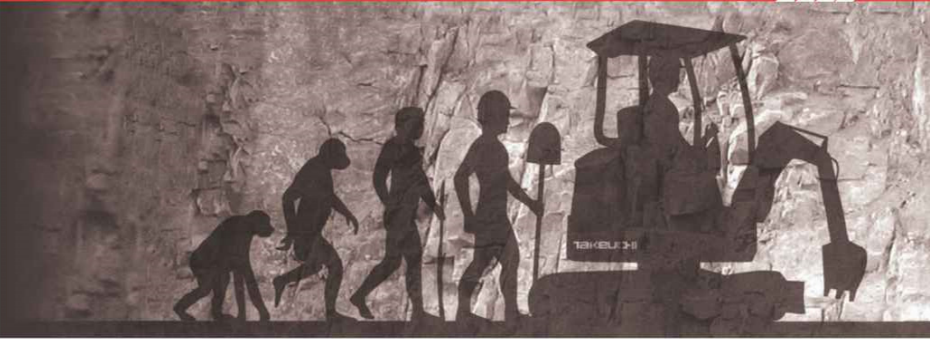

Mini TB219

FULL HYDRAULIC COMPACT EXCAVATOR

OPERATING RANGES (Long Arm) : mm

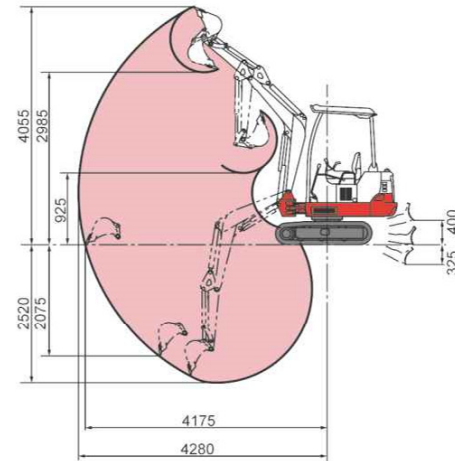

MACHINE DIMENSIONS : mm

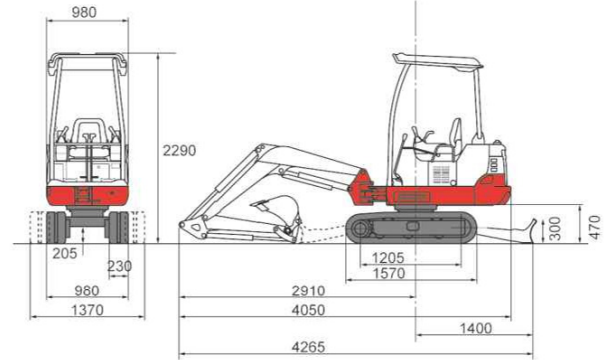
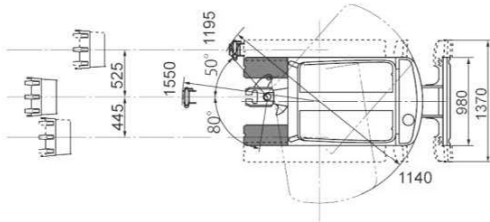

Weight			
Machine Weight	kg	Canopy 1945	Cabin 2070
Bucket			
Bucket Capacity (Heaped)	m ³	0.046 (Heaped)	
Bucket Width	mm	450	
Dozer Blade			
Width x Height	mm	980 / 1370 x 300	
Operating Range Up / Down	mm	400 / 325	
Diesel Engine (Water-Cooled)			
Model		3TNV70	
Cylinders / Type		3 / 4CYCL	
Rated Power	kW	11.5 / 2,500 min ⁻¹	

SPECIFICATIONS TB219

Maximum Torque	N·m	48.4 - 52.7
Displacement	mL	854
Engine Coolant	L	3.7
Engine Oil	L	2.8
Fuel Tank	L	24
Electric System	V·A·h	12-45
PERFORMANCE		
Traction Speed	km/h	2.4 / 4.0
Upper Slew Speed	min ⁻¹	8.7
Gradeability	degrees	15
Max Dig power Bucket	kN	16
Max Dig power Arm	kN	11.4

*Breaker Piping Standard

Ground Pressure	kPa	Canopy 31.1	Cabin 33.1
OFF-SET DIG FUNCTION			
Type		Boom Swing	
Swing Angle RH / LH (Cabin)		50° / 80°	
HYDRAULIC SYSTEM			
Pump type		Variable x 2 + Gear x 2	
Set Pressure	MPa	20.6 x 2 + 18.0 x 1	
Discharge	L/min	20.0 x 2 + 11.3 x 1	
Slew Motor		Orbit	
Traction Motor		Axial Piston	
Hydraulic Capacity	L	23	

FYN TECHNOLOGIES PVT. LTD.

A group company of Fine Equipments.

Fine Centre, Behind Shroff's Srushti,
Off Mumbai - Bangalore Highway, Mhalunge,
Pune 411045, INDIA.

Tel: +91 20 29808962

Mob: +91 83082 88600 / 93264 39921

Email: info@fineequipment.net

Web: www.fineequipment.net



Print: Feb.2019

**BOOM SWING
POWERFUL OPERATION
WORLD-CLASS SAFETY
EASY MAINTENANCE
ENVIRONMENT FRIENDLY
ROBUST AND COMFORTABLE
DOZER BLADE**

mini
TB 235



OPERATING RANGES:mm

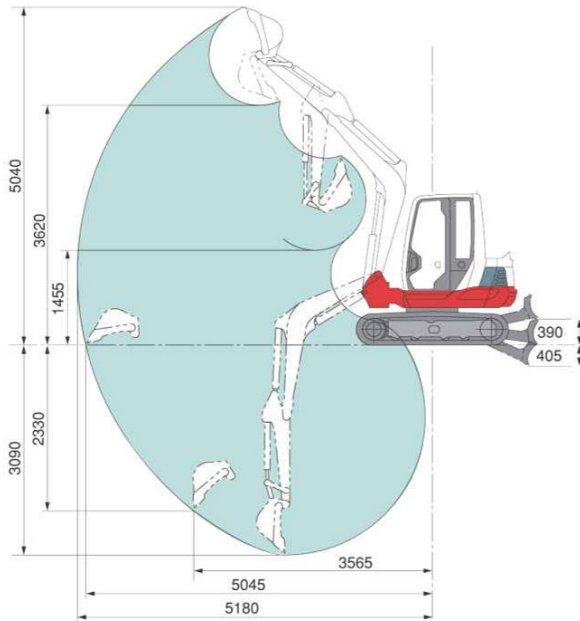

MACHINE DIMENSIONS :mm

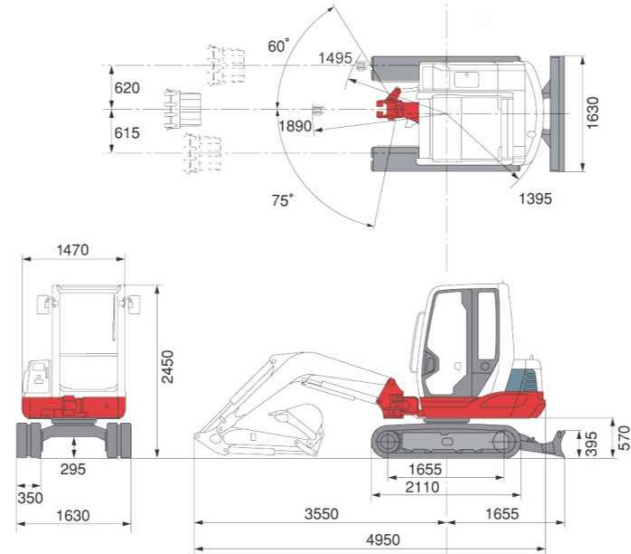

mini
TB235
FULL HYDRAULIC COMPACT EXCAVATOR

MIDDLE ARM

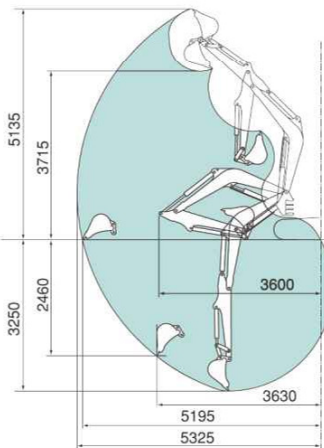

LONG ARM

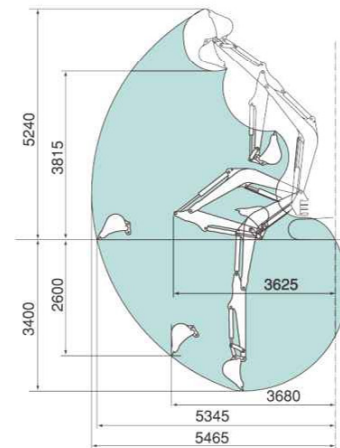

SPECIFICATIONS TB235 (Cab, Rubber Tracked, Standard Arm, Breaker Piping Standard)

Weight			Fuel Tank	L	53	Set Pressure	MPa	21.0 x 2 + 19.6 x 1 + 3.4 x 1
Operating Mass(ISO6016) kg	Canopy	3465	Electric System	V-A·h	12-73	Discharge	L/min	38.9 x 2 + 22.8 x 1 + 10.8 x 1
	Cabin	3605	PERFORMANCE			Slew Motor	Piston Motor	
Bucket			Traction Speed	km/h	2.6 / 5.0	Traction Motor	2-Speed Piston Motor	
Bucket Capacity (Heaped) m ³	0.105 (Heaped)		Gradeability	degrees	30°	Hydraulic Oil Capacity	35 (Level) / 67 (System)	
Bucket Width mm	570		Max Dig power Bucket	kN	27	SAFETY		
Diesel Engine (Water-Cooled)			Max Dig power Arm	kN	SSA: 18.3 MSA: 17.1 LSA: 16.0	ROPS / FOPS (CABIN / CANOPY)		
Model	3TNV88		Ground Pressure	kPa	Canopy 26.8	Cabin		ROPS / FOPS
Cylinders / Type	3/4CYCL		OFF-SET DIG FUNCTION			Option & Equipments		
Engine Power:kW(ISO 9249)	21.5/2,400 min ⁻¹		Type	Boom Swing		Service Port 1	L/min/MPa	62/ 21.0 (Standard)
Engine Power:kW(ISO 14396)	22.0/2,400 min ⁻¹		TRACTION SYSTEM			Service Port 2	L/min/MPa	23/ 19.6 (Option)
Engine Power:kW(SAE J1995)	22.5/2,400 min ⁻¹		Type	Rubber / Steel		Service Port 3 Flow Rate(A/B)	L/min	11/23 (Option)
Maximum Torque	N·m	98.6-107.4	HYDRAULIC SYSTEM			Service Port 3 Pressure(A/B)	MPa	3.4/19.6 (Option)
Displacement	mL	1642	Pump type	Variable x 2 + Gear x 2		Vibration levels (EN 12096:1997)		
Engine Coolant.	L	8.7				Hand/Arm	≦ 2.5m/s ²	
Engine Oil	L	4.7				Body	≦ 0.5m/s ²	

FYN TECHNOLOGIES PVT. LTD.

A group company of Fine Equipments.

Fine Centre, Behind Shroff's Srushti,
Off Mumbai - Bangalore Highway, Mhalunge,
Pune 411045, INDIA.

Tel: +91 20 29808962

Mob: +91 83082 88600 / 93264 39921

Email: info@fineequipment.net

Web: www.fineequipment.net



Print : Feb, 2019